

CAD FILE:

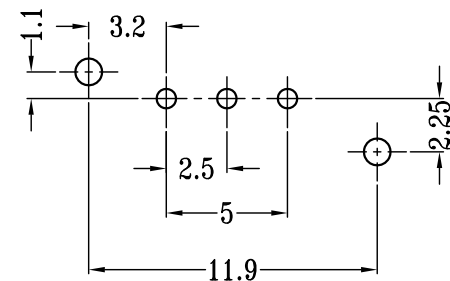
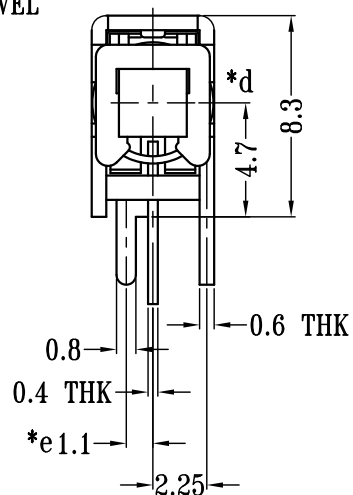
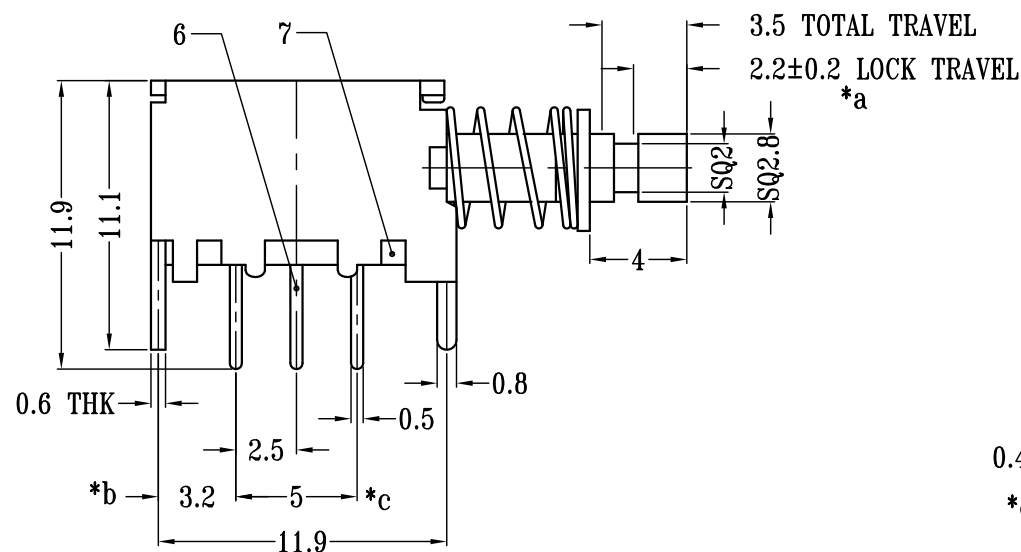
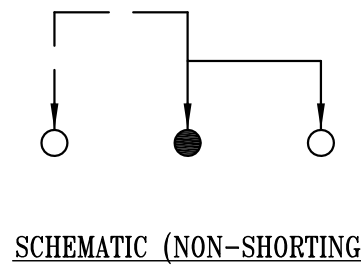
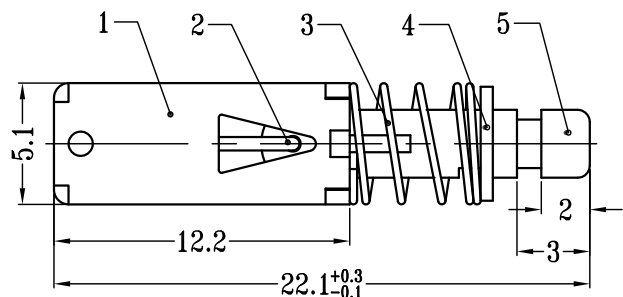

P.C.B LAYOUT
BOTTOM VIEW

注：“*”表示关键尺寸(5个).

9	CONTACT CLIP	PBS C5210R-EH	1	Ag CLAD
8	SPRING PLATE	PBS STRIP	1	NATURAL
7	BASE	PHENOLIC RESIN	1	NATURAL
6	TERMINAL	BRASS STRIP	3	Ag PLATED
5	KNOB	PA66	1	BLUE
4	BLOCK	STEEL STRIP	1	Ni PLATED
3	SPRING	STEEL WIRE	1	Ni PLATED
2	CAM STICK	PBS WIRE	1	NATURAL
1	FRAME	STEEL STRIP	1	Ni PLATED
NO.	PARTS	MATERIALS	Q'TY	FINISHING

TOLERANCE UNLESS SPECIFIED					
WITHIN 1.5mm : ±0.1mm	A	2019-9-22	初版		王远杰
OVER 1.5mm : ±0.2mm	ISSUE	DATE	DESCRIPTIONS OF REVISION		APPD.
TITLE : PUSH SWITCH		UNIT : mm	DRWG NO.: HQ-DR-PS12E05-00		
MODEL: PS12E05-BE-Cs		SCALE: 3:1	DWN.	王远杰	2019-9-22
东莞市铭标电子科技有限公司 Ming Mark Electronic Technology Co., Ltd.		RoHS	CHK'D	朱明华	2019-9-22
			APPD.		