



东莞市铭标电子科技有限公司
MINGBIAO ELECTRONICS CO., LTD

承 认 书

APPROVE SHEET

客户名称 Customer: _____

品 名 Part name: DIALWHEELSWITCH

型 号 Part Number: THMU34-X-R

Design/Date	Check/Date	Review/Date	Approval/Date

贵公司承认印 Approval signatures

Approval/Date	Remark

Send us a copy of reference , thank you! 日期 Date:

地址: 广东省东莞市长安镇沙头社区猫山东路 101 号

Add: Dongguan City, Guangdong Province, Chang'an Town, Sand head community The cat shandong road, No. 101

Ntel: 0769-81581583

更改日期	更改标记	更改说明	版次	文件编号

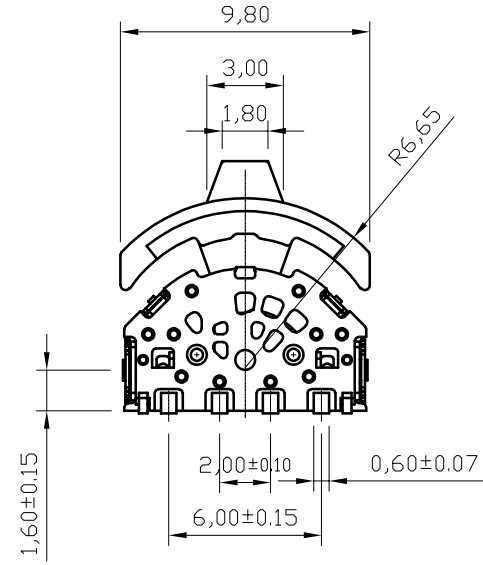
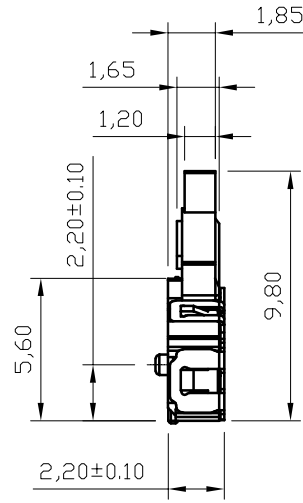
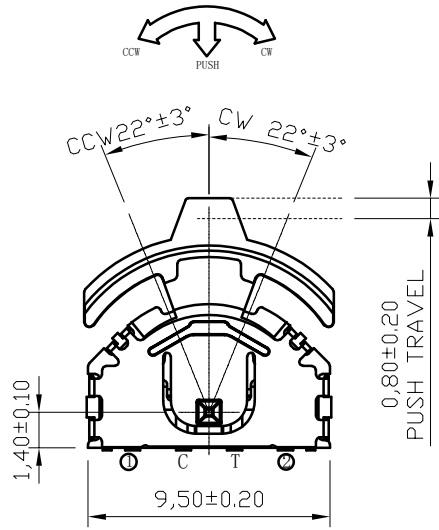

技术要求:

- 1、额定负载: DC 10V 5mA
- 2、接触电阻: 300mΩ Max
- 3、绝缘电阻: 100MΩ Min
- 4、耐压: AC 100V 50Hz/1min
- 5、行程: 0.8±0.20mm
拨动角度: 22±3°
- 6、操作力: 水平300±100gf
拨动80±50gf
- 7、寿命: 50000Min

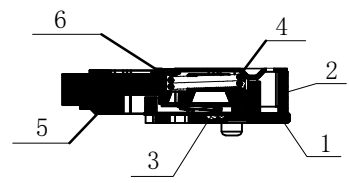
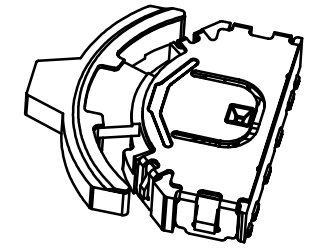
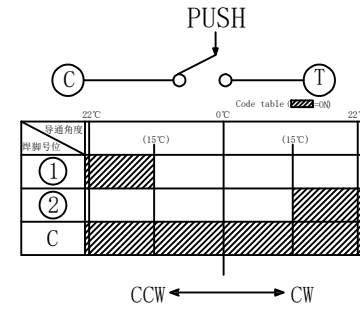
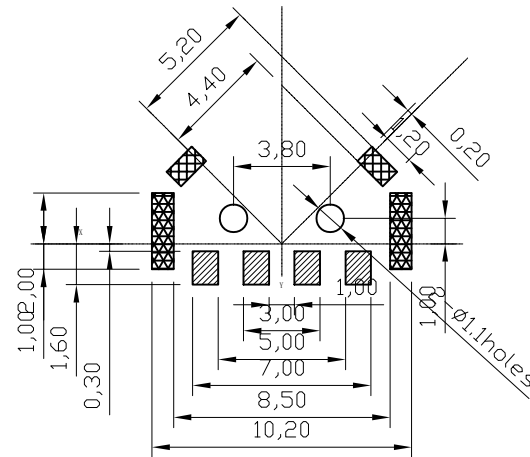
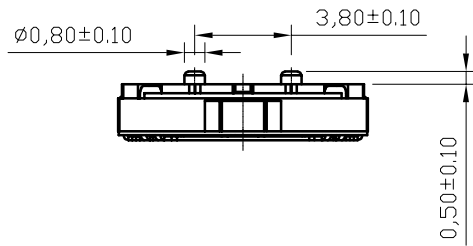

P. C. B. INSTALLATION DIAGRAM

CIRCUIT DIAGRAM

6	盖子	1	不锈钢镀银	
5	推柄	1	PPA 黑	
4	弹簧	1	不锈钢	
3	接触片	1	镀铜镀银	
2	底座	1	LCP 黑	
1	端脚	4	磷铜 镀银	
序号	零件名称	数量	材料	备注

未注公差		东莞市铭标电子科技有限公司 Ming Mark Electronic Technology Co., Ltd. RoHS				
线性公差	角度公差	±3°	品称	迷你摇头II型	角法	
50<L	±0.40		料号	THMU34-X-R	比例	
30<L≤50	±0.30			图号	SP3. 603. 011	1:1
10<L≤30	±0.20				页码	共1页 第1页
L≤10	±0.10	审核				页面
批准			页码	共1页 第1页	版次	
					A4	
					A/0	

TITLE	ENCODE SWITCH 迷你拨轮 II 型-开关	SPC. NO.	THMU34-X-R	DWN. NO.		Applied Customer	所有客户 ALL Sutomer
-------	-------------------------------	----------	------------	----------	--	------------------	---------------------

Packaging flow:
包装流程图



RoHS

✓	自粘 self-adhesive
	热封 heat seal

UNIT:mm

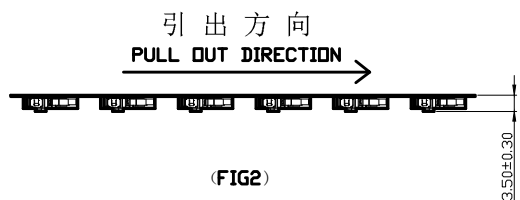
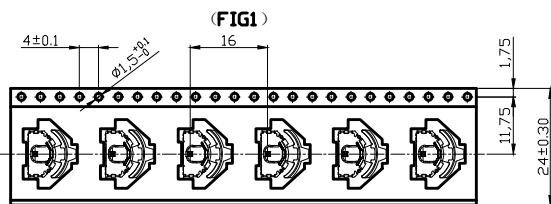
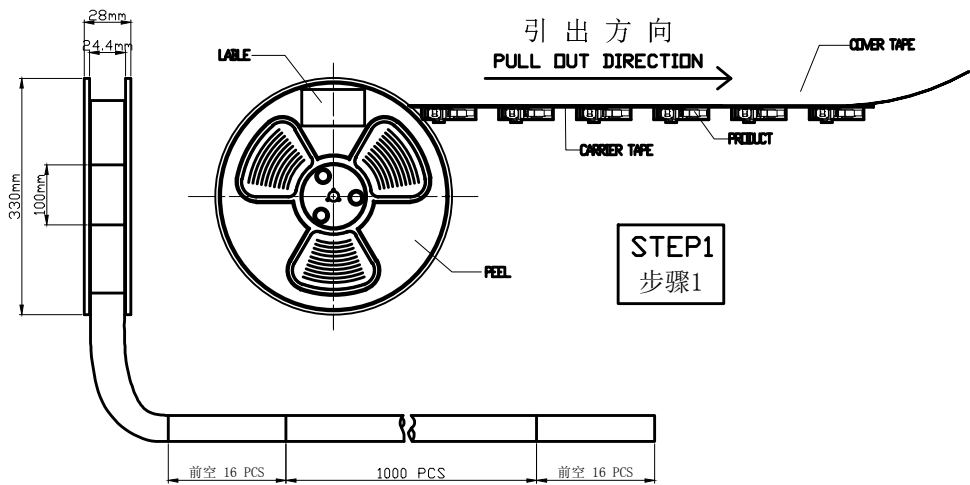

REMARK 备注:

- 1、Tape shall turn on right direction.
胶带应向右打开。
- 2、The direction of connector is fixed regarding the position of terminal, please refer outline drawing (refer FIG2).
关于开关的位置方向是固定的, 请参考外形图。(参考FIG2)
- 3、After winding using the adhesive tape (80~150mm) to stick the leader of cover tape on the side of reel.
缠绕完后 用80~150mm长度的美纹胶粘在载带上。
- 4、The label shall be pasted on the front side of reel (refer FIG3).
标签粘在卷带的正前方。(参考FIG3)
- 5、Condition of 300mm per minute, the extraction strength of cover tape shall reach 10~150gf.
以每分钟300mm 的速度条件, 胶带剥离力的强度将达到10~150gf

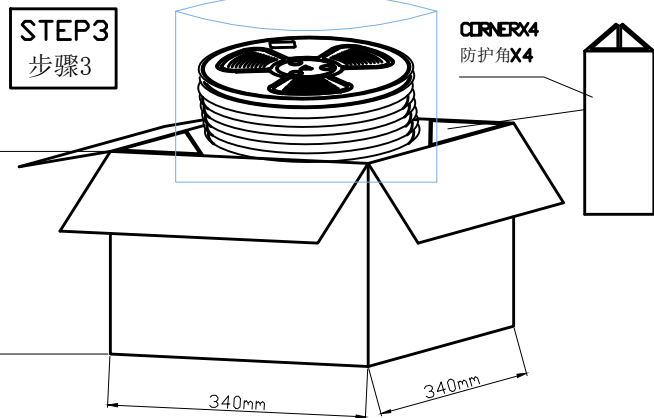
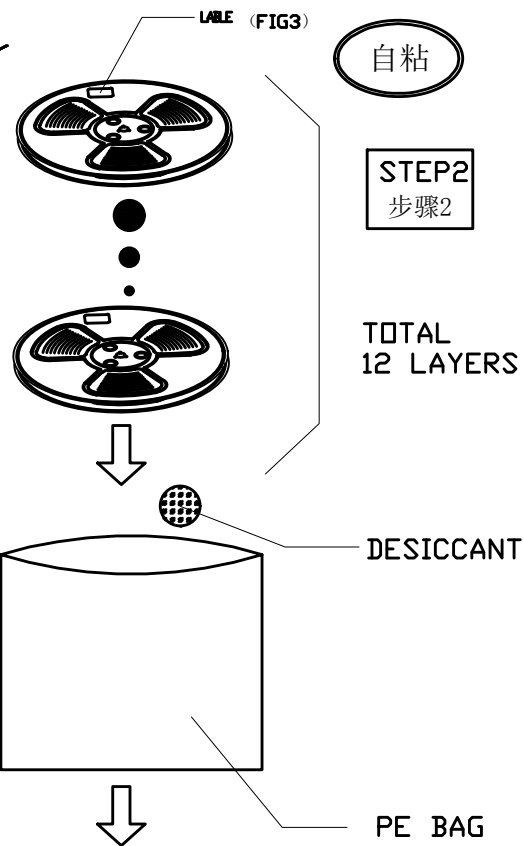

包装参数

Packaging parameters

1 CARTON (每箱)
=12 Reel (12 卷盘)
=1,000PCS /Reel*12
(每卷盘1,000 只)
=12,000PCS (共1.2 万只)

Notes: Label and mark pls according 《Customer label and mark management tabel》 to operate
备注: 标签和唛头请参照《客户标签和唛头管理表》执行

ISSUE	DATE	WRN	CHKD	APVD	DESCRIPTIONS

东莞铭标电子科技有限公司		文件编号	SP3.603.009
		发布日期	
PRODUCT SPECIFICATION 产品承认书		文件版本	第 A 版 第 0 次修订
SERIES 系列	DIAL WHEEL SWITCH 拨轮开关	页 数	共 4 页 第 1 页
1.General Characteristics 一般特性			
1.1 Application: This specification is applied to secondary circuit lever switch push-mechanism used for general applications. 适用范围:该规格书适用带按键功能摇头开关。			
1.2 Operating Temperature Range: -10°C to $+60^{\circ}\text{C}$ 使用温度范围: -10°C to $+60^{\circ}\text{C}$			
1.3 Operating Temperature Humidity: $\leq 85\%$ at $+40^{\circ}\text{C}$ 相对湿度: $\leq 85\%$ at $+40^{\circ}\text{C}$			
1.4 Test Conditions: Unless otherwise specified, the atmospheric conditions for making measurements and tests are as follows: 实验条件: 若没有特别说明, 则试验大气条件如下:			
Ambient Temperature: $5-35^{\circ}\text{C}$			
Relative Humidity: 45-85% RH			
Air Pressure: 86-106Kpa(860-1060mbar)			
环境温度: $5-35^{\circ}\text{C}$			
相对湿度: 45-85% RH			
大气压力: 86-106Kpa(860-1060mbar)			
2 Appearance , Structure & Dimensions 外观 , 结构及尺寸			
2.1 Appearance: The encoder shall have good finishing , and no rust , crack of plating defects 。 外观: 产品外观良好, 无锈蚀、裂纹和镀层缺陷。			
2.2 Structure & Dimensions : Refer to individual product drawing 。 结构及尺寸: 参见产品图纸			
2.3 Markings : Refer to individual product drawing 。 标识: 参见产品图纸			
3. Ratings 额定值: 10mA 5VDC (Each bit)			
4. Electrical Characteristics 电气特性			
NO	Item 项目	Criteria 标准	Test Method 实验方法
4.1	Contact	300m Ω Max	Lever-on switch 水平开关
	Resistance 接触电阻	300m Ω Max	Push-on switch 按键开关
4.2	Insulation Resistance 绝缘电阻	100M Ω Min	100VDC voltage is applied between each pair of terminals and between the terminal and the metal frame for $60 \pm 5\text{s}$ 。 在相互绝缘的所有端子之间及各接线端子与外露的非载流金属零件之间加载 100V 直流电, 持续时间 $60 \pm 5\text{s}$ 。
4.3	Output Voltage 输出电压	1V Max.	Shall be measured at 1ma 5VDC (Resistive load) Measure point is voltage lever。 Between ground and measuring terminal. 在相互绝缘的所有端子之间及各接线端子。 在外露的非载流金属零件之间, 加载 1mA, 5VDC 进行测量。
4.4	Voltage proof 抗电强度	No dielectric breakdown shall occur	100V AC(50~60Hz, cut -off current 2mA) is applied between non-connected terminals and between terminals and the metal frame for $60 \pm 5\text{s}$ 。
5. Mechanical Characteristics 机械特性			
Robustness of		Shall be free from appearance 、 operation and mechanical abnormalities 表面及结构无明显变形,功能无损坏。	A static load of 50N (3.1kgf) shall be applied in the push direction of actuator for 15s 。 沿操作元件按力方向均匀施工加静载 30N, 持续时间 15 秒。
			A static load of 10N(1.02kgf) shall be applied in the rotation direction of actuator for 15s

5.1	actuator 元件强度		<p>沿操作元件旋转的方向均匀施加静载 10N，持续时间 15 秒。</p> <p>A static load of 5N (0.51kgf) shall be applied in the perpendicular direction of operation at the tip of actuator for 15s.</p> <p>Switch shall be measured after securing to an Oblique line on frame 。 在操作元件末端沿垂直方向均匀加静载荷 5N ，持续时间 15 秒。 元件在外壳定位稳固后进行测量。</p>
5.2	Wobble of actuator 元件摆动	P-P: 2.mm max	<p>Run-out (P-P)shall be applying a static load of 1N(102gf)in the perpendicular direction of operation at the tip of actuator.</p> <p>在操作元件末端沿垂直方向均匀施加静载荷 1N，测量 P - P 值 /</p>
5.3	Vibration proof 振动	<p>A fter test, Contact resistance:10Ω Max. Insulation resistance:10M Ω Min No abnormalities shall be recognized in appearance and construction 实验后: 接触电阻: 10Ω Max。 绝缘电阻: 10 M Ω Min。 表面及结构无明显变形。</p>	<p>Encoder shall be secured to a testing machine by a normal Mounting device and method encoder shall be measured after following test.</p> <p>(1) Vibration frequency range=10~55Hz (2) Total amplitude =1.5mm (3) Sweep ratio : 10~15~10Hz Approx.1min (4) Method of changing the sweep vibration frequency; logarithmic or linear. (5) Direction of vibration: Three perpendicular directions including or linear (6) Duration: 2 hours.(6 hours in total)</p> <p>开关采用常规的安装方法牢固地安装在试验设备上，并在下述参数条件下进行试验:</p> <p>(1) 振频=10~55Hz (2) 振幅度 1.5mm (3) 振动变化速率: 10~15~10Hz 大约 1 分钟 (4) 变频方法: 对数或线性型式 (5) 振动方向: 三个相互垂直的方向，其中一个方向应是促动元件运动的方向。 (6) 时间: 每个方向 2 小时 (共 6 小时)。</p>
5.4	Mechanical Shock 冲击	<p>After test, Contact resistance:10Ωmax Insulation resistance:10M Ω Min The Electrical performance Requirements specified in item 4.4shall be satisfied. Shall be free from mechanical abnormalities. 实验后: 接触电阻: 10Ω Max 绝缘电阻: 10M Ω Min 电气性能符合每 4.4 条的要求。 表面无变形且操作正常。</p>	<p>Switch shall be measured after following test:</p> <p>(1) Mounting Method :Normal (2) Acceleration: 490m/s² (50G) (3) Duration: 11ms (4) Test Direction:6 directions (5) Number of shouks :3 times per direction(18times in total)</p> <p>试件在下述参数条件下进行试验:</p> <p>(1) 安装方法: 常规方法 (2) 加速度: 490m/s² (50G) (3) 时间: 11ms (4) 实验方向: 图示 6 方向 (5) 冲击次数: 每个方向 3 次 (总共 18 次)</p>

5.5	Robustness of terminal 端子强度	Shall be free from terminal looseness, damage and insulator breakage. The electrical performance requirements specified in section 4 shall be satisfied. 端子无松动, 损坏及绝缘层的破裂, 电气性能应符合第 4.4 条的要求。	A static load of 3N(306gf) shall be applied to the tip of terminal in a desired direction for 1min the shall be bone once per terminal. 以 3N 作用力沿轴向逐渐施加于接线端末端, 作用力方向为离开开关向外指向, 每个接线端子测量一次。	
5.6	Operating force 操作力	Push portion:300±100gf Lever position:80±50gf 按力方向: 300±100gf 水平方向: 80±50gf	A static load shall be applied to the tip of actuator in operating direction 在操作元件末端沿操作方向均匀施加静载荷。	
5.7	Solder Heat Resistance 耐焊接热	No abnormalities shall be observed in appearance and Operation. 无外观及功能损坏	Encoder shall be measured after following test: (1) Conditions stated are for 0.8mm thick glass epoxy P.C.B. (2) Re-flow soldering equipment: infrared heater (3) Temperature measurement point to the copper plated side on the P.B.C surface. (4) Re-flowing conditions must be determined after first checking the actual equipment and circuit board be used. (5) Be careful to prevent molten solder from coming into birect contact with the main body of the switch when installing the switch on a through-hole type circuit board. 试件在下列参数条件下进行试验: (1)P.C.B 厚度 0.8mm. (2)同流通焊设备: 红外线加热器。 (3)温度测定点: P.C.B 板表面铜箔部。 (4)在使用装置, 基板固定后测试。 (5)试件安装在线路上后, 要小心注意。 Temperature profile(Reference)	
6.1	Mechanical Life 机械寿命	After test, Contact resistance:1 Ω Max .insulation resistance:100M Ω Min Operating force: Push portlon:350±100gf Lever portion:100±50gf The Encoder shall be free from abnormalities in appearance construction.	Lever Portion 按力方向	Switch shall be operated 50,000 cycles a 15~20 cycles/min without load. 速度为 15~20 次/分, 在寿命设备上连续转换 50,000
	Electronics Life 电气寿命	实验后: 接触电阻: 1Ω Max 绝缘电阻: 100M Ω Min 操作力范围: 按力方向: 350±100gf 水平方向: 100±50gf 开关外观及结构应无损坏。	Lever Portion] 水平方向	
			Push Portion 按力方向	Switch shall be operated 50,000 cycles a 15~20 Cycles/min with 5V DC 10Ma(resistance load) 在 10mA 5V DC 条件下, 速度为 15~20 次/分, 在寿命试验设备上连续转换 50,000 次。

7. Weather proof Characteristics		耐候性能:	
7.1	Cold Proof 低温	After test, Contact resistance:1Ω Max.	After testing at $-40 \pm 2^{\circ}\text{C}$ for 96 hours, the encoder shall be allowed to stand under normal temperature and humidity conditions for 1 hour, and measurement shall be made within 1 hour after that . water drops shall be eliminated. 试件在 $-40 \pm 2^{\circ}\text{C}$ 的温控箱内保持 96 小时,然后在正常温度和湿度下恢复 1 小时,并在此后 1 小时内对试品时行测量,水滴应消失。
7.2	Hot PROOF 低温	Insulation resistance: 100M Ω Min The Encoder shall be free from abnormalities in appearance and construction.	After testing at $85 \pm 2^{\circ}\text{C}$ for 96 hours, the encoder shall be allowed to stand under normal temperature and humidity conditions for 1hour, and measurement shall be made within 1 hour after that . 试件在 $85 \pm 2^{\circ}\text{C}$ 的温度控箱内保持 96 小时,然后在正常温度和湿度下恢复 1 小时,并在此后 1 小时内对试品进行测量,水滴应消失。
7.3	Moisture Resistance 恒定湿热	实验后: 接触电阻: 1Ω Max. 绝缘电阻: 100M Ω Min 开关外观及结构应无损坏	After testing at $40 \pm 2^{\circ}\text{C}$,90-95%RH for 96 hours, the Encoder shall be allowed to stand under normal temperature and humidity conditions for 1 hour and measurement shall be made within 1 hour after that. Water drops shall be eliminated. 试件在 $40 \pm 2^{\circ}\text{C}$,90-95%RH 的温控箱内保持 96 小时,然后在正常温度和湿度下恢复 1 小时,并在此后 1 小时内对试品进行测量,水滴应消失。
7.4	Temperature Cycling 温度转换]After test, Contact resistance: 1Ω Max Insulation resistance: 100M Ω Min The encoder shall be free from abnormalities in appearance and construction. 实验后: 接触电阻: 1Ω Max 绝缘电阻: 100M Ω Min 开关外观及结构应无损坏。	After 5 cycles of following conditions, the encoder shall be allowed to stand under normal temperature and humidity conditions for 1 hour, and measurement shall be made within 1 hour after that. Water drops shall be eliminated. 试件按下述实验条件试验 5 次,然后在正常温度和温度下恢复 1 小时,并在此后 1 小时内对试品进行测量,水滴应消失。
7.5	Salt Mist 盐雾实验	No remarkable corrosion shall be recognized in metal part, 在金属件没有腐蚀斑点。	The encoder shall be checked after following test: (1) temperature: $35 \pm 2^{\circ}\text{C}$ (2) Salt Solution: $5 \pm 1\%$ (Solids by mass),immersing time:5minute (3) After immersing,salt deposit shall removed by running water. (4) Duration:24hour 试件在下述实验合测量: (1) 温度: $35 \pm 2^{\circ}\text{C}$ (2) 盐溶液浓度: $5 \pm 1\%$ (质量百分比), 浸泡 5 分钟。 (3) 浸泡后, 盐沉积物用水冲掉。 (4) 时间: 24 小时